



Owners Manual

50Hz Aerator & Circulators

Contents

Important Safety Instructionspg2
General description of equipment and functionpg2
Intended use and limits of usepg2
Installation requirementspg2
Unit Specspg3
Utility requirementspg3
Quick Disconnect Installationpg3
Wire Sizing & Gland Sizingpg5
2400EA, 3400EA, 4400EA Aerator Partspg6
2400EA, 3400EA, 4400EA Assemblypg7
8400EA, 2.3EA, 3.1EA, 3.3EA Partspg9
8400EA, 2.3EA, 3.1EA, 3.3EA Assemblypg9
3 Phase Startup Procedurepg10
Installation Instructionspg11
Circulator Parts (EC Models)pg12
Circulator (EC Model) Assemblypg12
Maintenance Recommendationspg14
Troubleshooting Tipspg16

Kasco Marine, Inc.
800 Deere Rd.
Prescott, WI 54021
U.S.A.

PH 00+1+715+262+4488
FAX 00+1+715+262+4487
sales@kascomarine.com
www.kascomarine.com





These international safety symbols are used throughout this manual to inform the owner of important safety information and notices for safe and effective use of the equipment.

Important Safety Instructions



- **Under NO circumstances should anyone enter the water with the electrical equipment connected and/or in operation. It is NEVER recommended to enter the water with the equipment in operation.**
- **Caution should be used when dealing with any electrical equipment with moving parts.**
- **NEVER run the unit out of water. It will damage the seals and create a dangerous situation for the operator.**
- **Extreme caution should be used around water, especially cold water, such as in Spring, Fall, and Winter, which poses a hazard in and of itself.**
- **NEVER lift or drag the unit by the power or light cord. If you need to pull the unit to the side of the pond, use the anchoring ropes.**
- **Do not use waders in deep ponds/lakes or ponds/lakes with drop-offs, drastic slopes, or soft bottom material.**
- **Do not use boats that tip easily for fountain installation, such as a canoe, and follow all boating safety rules and regulations, including wearing a PFD. (Personal Flotation Device)**
- **The unit is supplied with an internal grounding conductor. To reduce the risk of electrical shock, be certain that the unit is plugged/connected to an approved RCD (GFCI) protected circuit.**
- **A properly sized 3 phase motor control (motor starter) with overload and short circuit protection must be provided at time of installation.**
- **3 phase units (2.3, 3.3) require a startup test**

after wiring to ensure proper rotation of the impeller. If the impeller is rotating in the opposite direction, the unit will not perform properly and internal damage to the unit may occur. (See 3 phase startup procedure)

- **Means for disconnection must be incorporated in the fixed wiring in accordance with local and national wiring rules to prevent accidental start.**
- **Consult a qualified electrician for electrical installation.**

General description of equipment and function

Electrically driven submersible propeller pump to mix and agitate water to improve water quality.

Intended use and limits of use

Kasco equipment is only intended for specific uses as detailed in this owner's manual. Intentional misuse could result in injury, damage to the product, and surrounding property.

Intended uses are as follows:

Aerators/circulators: To provide aeration and water circulation to bodies of water such as ponds, lakes, bays, marinas, docks, fish farms, and aeration tanks for processed water. Aerators/Circulators should only be installed and operated in areas where no swimming is allowed and where no one will enter the water during operation of the unit. Installation must be completed as detailed in the installation manual.

Installation, adjustment, maintenance, and removal of this equipment should be limited to experienced maintenance persons or trained professionals. If you are not sure how to install or operate any Kasco products call your local distributor, contact an electrician, or contact Kasco customer service at www.kascomarine.com for further assistance.

Installation requirements

- Read and understand all instructions and safety warnings prior to installation and use.
- Equipment must be installed as required by the instructions.
- Do not use this equipment outside of its intended purpose, or if site conditions would pose a danger-

ous installation.

- To be installed and operated only by an adult. Not to be used by children.
- Never install in areas where swimming is allowed or where people enter the water.
- Never use in a swimming pool.
- Do not use this equipment for intentional weed removal, sediment removal or dredging.
- Follow all local and national electrical wiring rules for the electrical circuit feeding this equipment. Failure to comply may result in injury.
- All equipment must be powered from an RCD (residual current device) or GFCI (ground fault circuit interrupter) protected circuit.
- Do not modify any mounting hardware or guarding provided with this equipment. All guarding purchased with a unit must be installed.
- This equipment is intended to operate without interaction from personnel. Never to be manipulated, moved, maintained, or adjusted while in operation. Damage or injury could result.
- The general public must be made aware of the installation and warned of the installation to prevent misuse or interference with the equipment.
- This equipment is intended to be used in water only. The equipment should only be operated out of water if required to troubleshoot operation and during initial startup of the equipment. The instructions provide detailed warnings and instructions for such activities and should only be performed by a trained person.

Unit Specs

Model	Voltage range	Operating amps	lock rotor amps
2400EA	208-240	2.2@220V	6@220V
3400EA	208-240	3.4@220V	9@220V
4400EA	208-240	3.7@220V	20@220V
8400EA	208-240	8.0@220V	40@220V
3.1EA	208-240	11.9@220V	60@220V
2400EC	208-240	2.2@220V	6@220V
3400EC	208-240	3.4@220V	9@220V
4400EC	208-240	3.7@220V	20@220V
2.3EA	190	5.2	41
2.3EHA	380	2.6	21

Model	Voltage range	Operating amps	lock rotor amps
3.3EA	190	8.2	69
3.3EHA	380	4.1	34

Utility requirements

The Electrical circuit must be provided to supply sufficient voltage and amperage to the unit. These ratings are listed in the above table (unit specs). This circuit must also include a disconnect means and short circuit protection.

Quick Disconnect Installation

Important – Read Carefully Before Installation

Before using the connector, it is important that these instructions are carefully read and understood to ensure the connector system is completely water tight and electrically safe.

IF IN DOUBT CONSULT A QUALIFIED ELECTRICIAN.

The socket (female) insert of the connector must be the live part of the connector from the supply. The pin (male) insert of the connector must lead to the load or electrical device. On 50Hz units, the pin (male) insert of the connector is installed at the factory. To ensure efficient sealing, use only smooth circular cable.

Pin Insert (Installed on Stub Cord)



Socket Insert (User Installed)



Note:

White gland for 9-11mm O.D.
Yellow gland for 13-15mm O.D.

Assembly/Wiring Instructions

STEP ONE

Remove the socket insert from the housing of the connector. There is a slot for a flat blade screwdriver in the center of the insert.



Note: The inserts have a LEFT HAND THREAD and should be turned clockwise to remove.

STEP TWO

Remove the gland nut and gland from the rear of the housing and slide on to the cable. Make sure the gland is orientated with the stepped edge facing the gland nut (see picture).



STEP THREE

Prepare the cable and strip wire ends as shown.

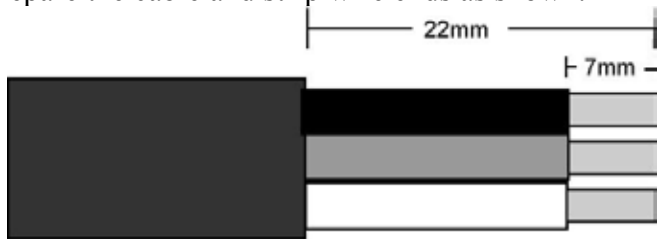

Wire Stripping

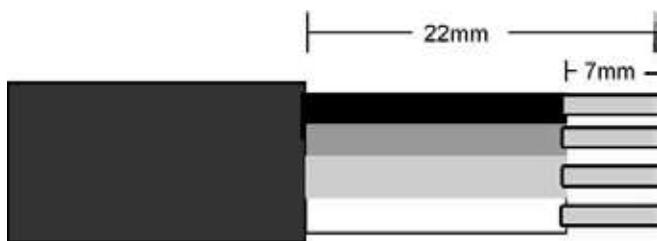

Wire Stripping

STEP FOUR

Insert the stripped wire ends into the terminals on the back of the Pin/Socket insert and fully tighten the wire retention screws. (Refer to figure for correct wire orientation).

Single phase wiring:



Figure 5:
Wire Connections
Brown wire to terminal L
Blue wire to terminal N
Green/Yellow wire to terminal E

3 phase wiring:



Figure 6:
Wire Connections
Brown wire to terminal 1
Black wire to terminal 2
Grey wire to terminal 3
Green/Yellow wire to terminal E

After the wires have been connected securely, pull the cable and insert back into the housing and tighten with a screwdriver to ensure the insert is seated correctly.



Note: LEFT HAND THREAD, turn the insert counter clockwise to tighten.

STEP FIVE

Prepare your supplied Resin Kit by removing the cap from the resin tube and pushing the resin nozzle onto the tube. Then twist the nozzle to lock in place.



Before applying to the quick disconnect, use the plunger to evenly push out a small amount of resin to get a proper mix of the 2-part epoxy. Then apply resin into the housing, enough to cover the wires and contacts. The resin should be about 3mm onto the cord jacket. Note: Adding too much resin may cause excess to be forced into the female end of the pin connector, preventing proper connection of the two halves.



 Cut-Away disconnect shown with clear resin. Note amount that is covering cord jacket.

then be attached to the float.



STEP SIX

Slide the gland and gland nut along the cable into the body and tighten the gland nut securely. No drying time is needed for the epoxy before full assembly.



STEP SEVEN

Once the two subassemblies have been completed, they can be joined together. Plug pin assembly into the socket assembly and tighten the large blue nut securely. The blue nut should be hand tightened only. (See figure below).



Note: There is a small gap after tightening

For seasonal removal, your quick disconnect includes an optional water tight cover. Simply separate the quick disconnect and insert the sealing cover into the large blue nut half and tighten firmly.

Strain Relief

The Strain Relief must be installed to protect the Quick Disconnect from damage due to excessive strain. The Strain Relief should be installed on the user supplied cord length (not on the Kasco supplied stub cord). It should be position about 15cm from the Quick Disconnect. To install, insert the narrow end of the elongated clamp with the chain connected into the wide end of the short clamp. Use a rubber mallet to tap the two pieces together securely. A Nylon Tie can be used to keep it attached to the cord. The chain can

Wire Sizing & Gland Sizing

The chart below shows the proper Gland to be used with different cord sizes. The measurements are based on the Outside Diameter (O.D.) of the cord. Smooth, round cords should be used.

Kasco Quick Disconnect 50 Hz Size Chart:

Gland	O.D. of Cord
Grey	7-9mm
White	9-11mm
Black	11-13mm
Yellow	13-15mm

Kasco 50 Hz Equipment Wire Size Chart

Model	Cord Length			
	10m	30m	60m	90m
2400EA	1.5mm ²	1.5mm ²	2.5mm ²	2.5mm ²
2400EC	1.5mm ²	1.5mm ²	2.5mm ²	2.5mm ²
3400EA	1.5mm ²	1.5mm ²	2.5mm ²	2.5mm ²
3400EC	1.5mm ²	1.5mm ²	2.5mm ²	2.5mm ²
4400EA	1.5mm ²	1.5mm ²	2.5mm ²	4mm ²
4400EC	1.5mm ²	1.5mm ²	2.5mm ²	4mm ²
8400EA	1.5mm ²	2.5mm ²	4mm ²	6mm ²
3.1EA	1.5mm ²	2.5mm ²	6mm ²	6mm ²
2.3EA	2.5mm ²	2.5mm ²	2.5mm ²	4mm ²
3.3EA	2.5mm ²	2.5mm ²	4mm ²	6mm ²
2.3EHA	2.5mm ²	2.5mm ²	2.5mm ²	2.5mm ²
3.3EHA	2.5mm ²	2.5mm ²	2.5mm ²	2.5mm ²

2400EA, 3400EA, 4400EA Aerator Parts

1. Aerator (Unit with cord or unit with Disconnect) (1)
2. Float (with two 50' mooring ropes attached) (1)
3. 1/4-20 x 3 1/2" Phillips Pan Head Screw (3)
4. 1/4" split washers (3)
5. 1/4" (3/4" outer diameter) Flat Washer (3)
6. Float Retaining Clips (3)
- (Optional bottom screen)
7. 3/8"-16 x 1-3/8" Hex Head Bolt (2)
8. 3/8" Flat Washer (4)
9. Bottom Screen cushions (4)
10. Bottom Screen (1)
11. Bottom Screen Clips (2)
12. 3/8"-16 Nylon Lock Nut (2)

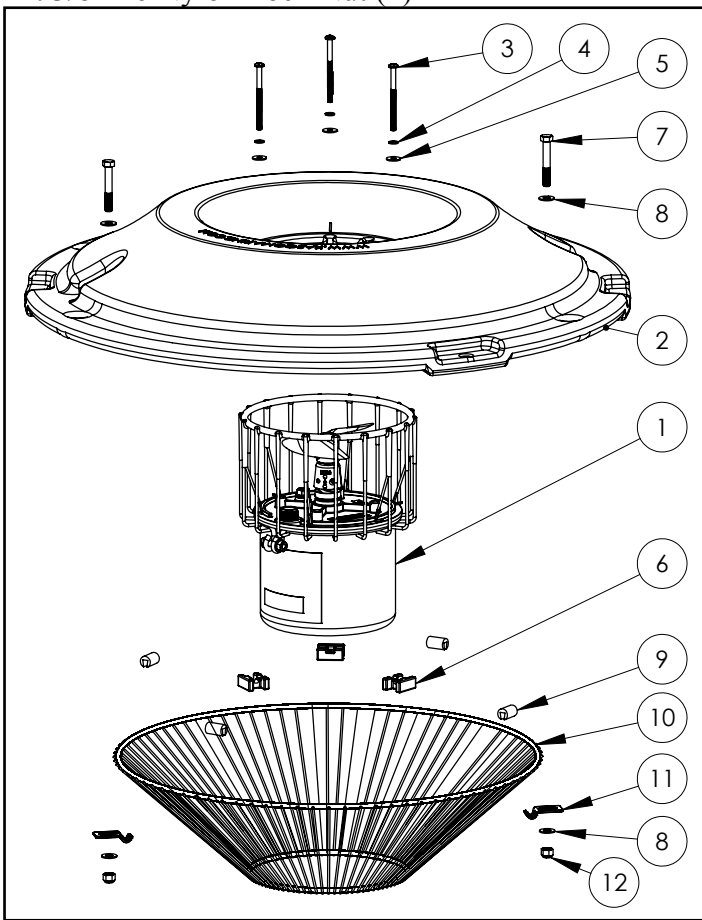

2400EA, 3400EA, 4400EA Assembly

1. Rest float on the cage

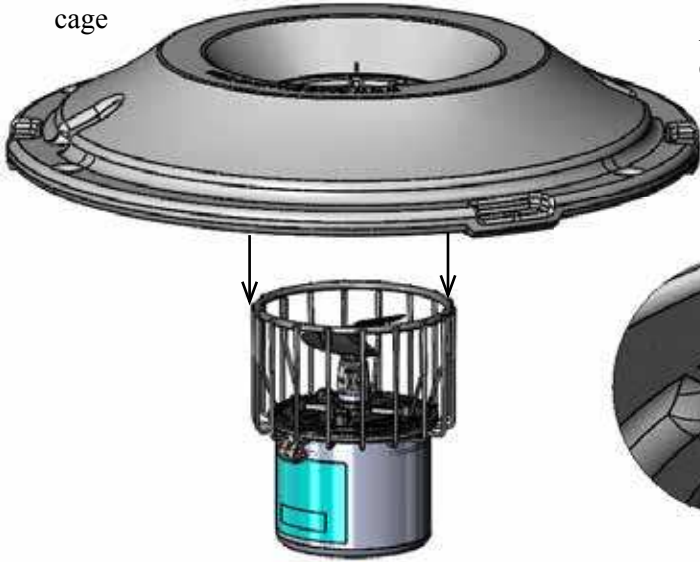

Align power cord with notch

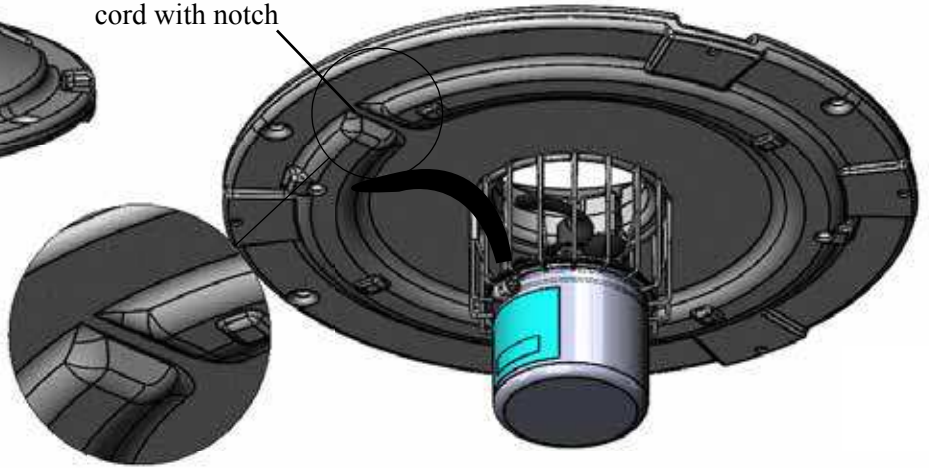

The 3 bolts should be placed equally spaced around the float in the bolt holes by the indicator mark

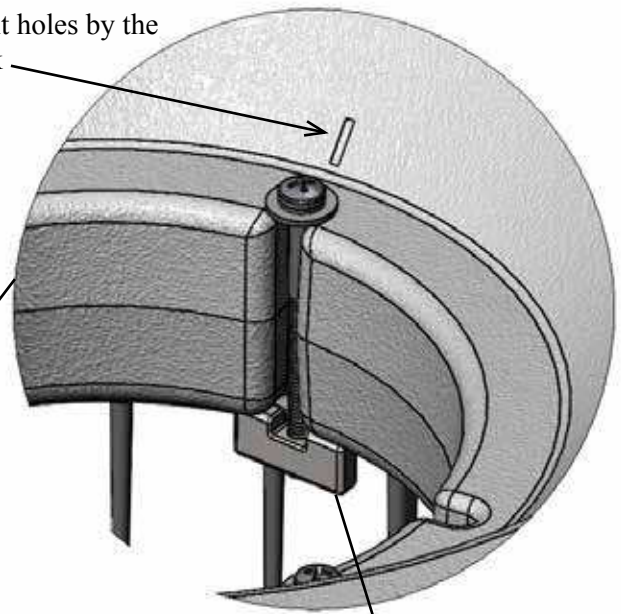

2. Secure float to cage with bolts and retaining clips. Lock washer goes between bolt and flat washer. Tighten down in 3 places to the float retaining clips

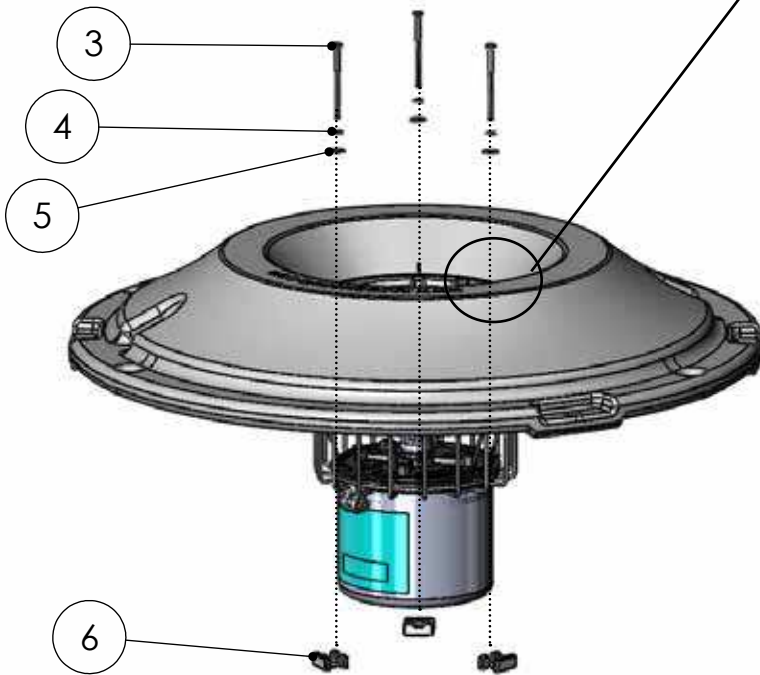

Secure to top ring of cage



Optional Bottom Screen attachment.

3. Turn upside down

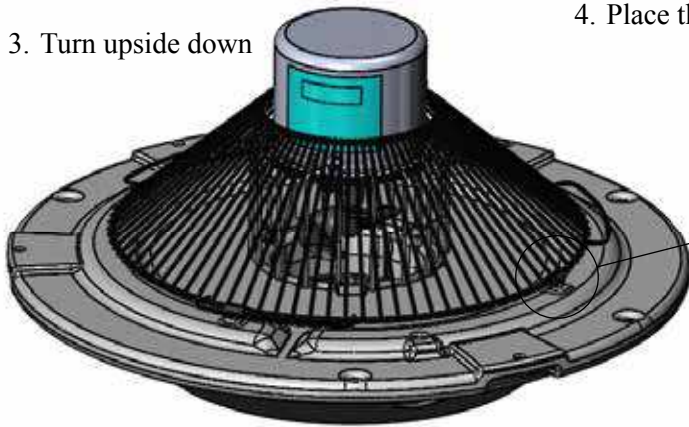

4. Place the bottom screen onto the float



5. Place the bottom screen cushions under the float on the 4 bumps

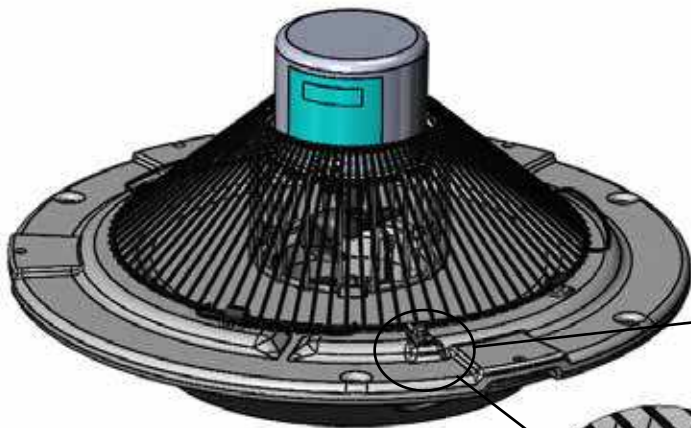

6. Secure the bottom screen to the float with the screen clip and hardware.

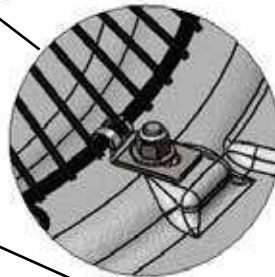

The two prongs on the clip should straddle a wire on the screen

7. Secure power cord to rope hole.

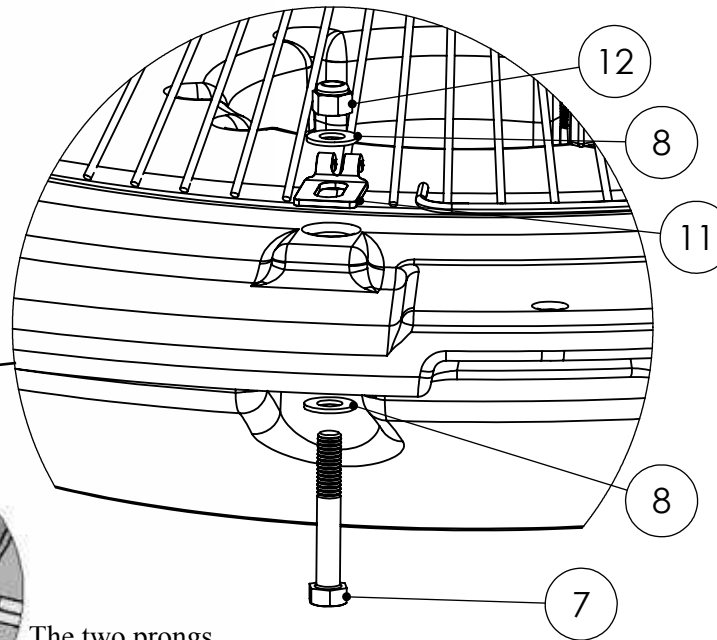
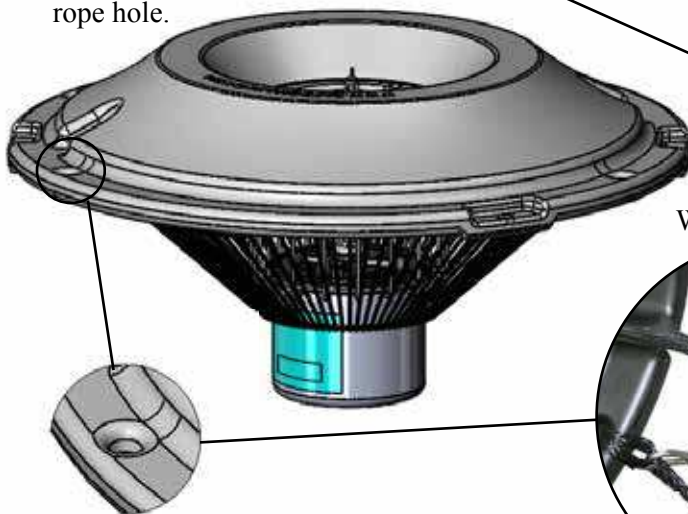

With Strain Relief



Without Strain Relief



OR

8. If ready to install in the pond, go to Installation instructions.

8400EA, 2.3EA, 3.1EA, 3.3EA Parts

B2. Large Float Ring

See Diagram below.

1. Float Section (3)
2. Top Float Bracket (3)
3. Bottom Float Bracket w/Rope (3)
4. 9" x 3/8" Bolt (6)
5. 3/8" Lock Nut (6)
6. 3/8" x 1" Bolt (3)
7. 3/8" Lock Washer (3)
8. Bottom Screen (1 - optional)
9. Bottom Screen Clips (3 - optional)

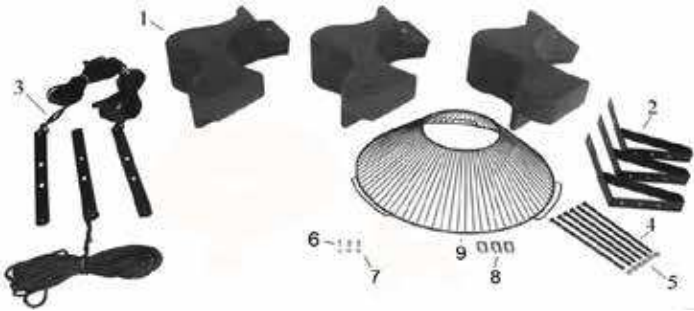

Note: Extra hardware may be included.

Tools & Supplies Needed:

- A. Anchors or stakes for installing unit (2 or 3 depending on unit)
- B. 208-240V Electrical Supply near pond on a post
- C. Two (or 3 depending on model) 30cm pieces of 2.54cm galvanized pipe for weighting ropes (optional)
- D. 9/16" (14mm) & 7/16" (11mm) Nut Driver
- E. 9/16" (14mm) & 7/16" (11mm) Socket Adjustable crescent wrench

8400EA, 2.3EA, 3.1EA, 3.3EA Assembly



Note: All provided guards and accessories must be installed as detailed in these assembly instructions.

STEP ONE

Remove all contents from package and place on a clean, flat surface. Inspect the shipment for any damages. Make sure you have all the parts needed.

STEP TWO

Arrange the three Float Sections (Part B1) upright (plug on bottom) so the overlap of one section aligns

with the next section and loosely push the three sections together to form a continuous ring.

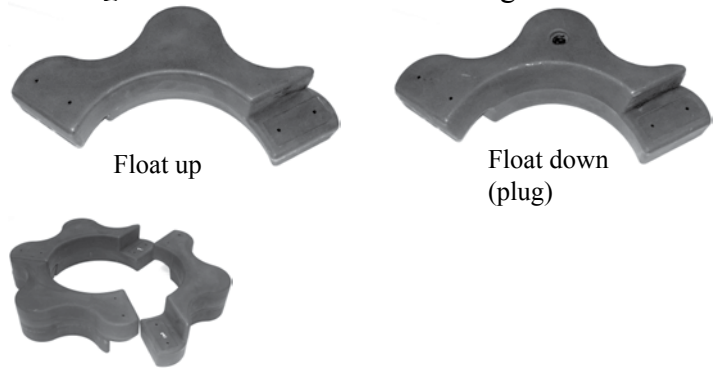

STEP THREE

Position one Top Float Bracket (Part B2) so that the bolt holes in the bracket align with the bolt holes in the two adjoined float sections and insert two 9" Black Coated Bolts (Part B4) through the assembly. This may require some minor repositioning of the float sections as you push the bolt all the way through. Do not force the bolt through. Repeat for the remaining two joints.



STEP FOUR

Turn the assembly upside down and place the Bottom Float Brackets (Part B3) over the bolts, the ends of which should now be extending through the assembly. Loosely install the six Lock Nuts (Part B5) on the ends of the bolts (do not tighten yet).

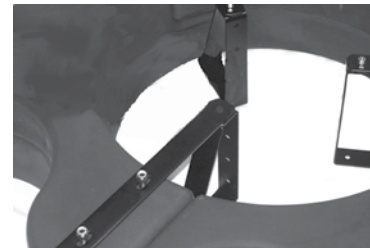

STEP FIVE

If the optional Bottom Screen (Part#B8) was purchased, place the Aerator Assembly inside the bottom Screen as shown.



STEP SIX

Lift Float Assembly and place over Aerator Assembly. Place the 3/8" x 1" Bolts (Part #B6) and 3/8" Lock Washers (Part #B7) through the top float bracket and lower float bracket as shown and screw directly into the aerator mounting ring. Tighten down with a 9/16" (14mm) wrench.

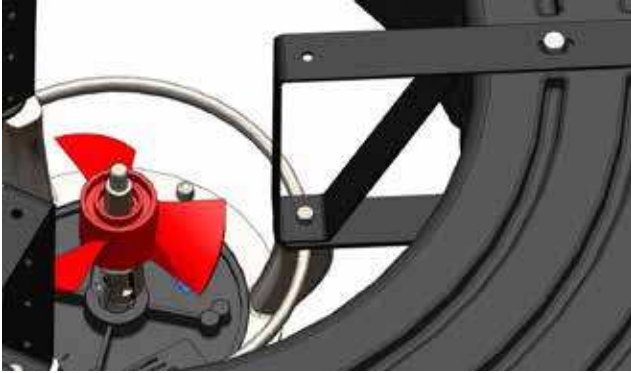

STEP SEVEN

(Optional Bottom Screen: purchased separately)
Position the Bottom Screen (Part B8) over the float so the motor housing (can) passes through the large hole in the center of the screen. Remove the center three Lock Nuts from the 9" Bolts and place the Bottom Screen Clips (Part B9) over the bolts as shown. The power cord can be slid under the bottom screen where two float sections come together before the Lock Nuts are replaced. Replace the three inside Lock Nuts and tighten all 3/8" Lock Nuts using the 9/16" (14mm) wrench and socket.



Note: Extra hardware may be included

STEP NINE

The user supplied power cord should now be attached to the stub cord by lining up the male and female halves of the disconnect and hand tightening the blue collar. On these cords, the Additional Strain Relief should be attached to one of the lower float brackets. If there is not a Strain Relief, use the Nylon Cable Tie provided to secure the cord to a rope to prevent damage by the propeller. If installing a new Quick Dis-

connect, please refer to Quick Disconnect instructions.

3 Phase Startup Procedure

A Control Panel is not provided with your unit, please refer to the following warnings:

When inherent overheating protection is not provided: use with approved motor control that matches motor input in full load amperes with overload element(s) selected or adjusted in accordance with control instructions.

Proper ground fault protection (RCD) must be provided at time of installation in your control panel

Note: The motor input in full load amperes is the marked value or the service factor amperes, shown on the nameplate.

<i>3 phase 190 volt</i>	2.3EA	3.3EA
Full load amps	5.2	8.2

<i>3 phase 380 volt</i>	2.3EHA	3.3EHA
Full load amps	2.6	4.1

Control panels must be installed by a qualified electrician.

If unit is connected to a circuit protected by a fuse, use a time-delay fuse with this pump.

You must verify motor rotation before installing the unit in the water.

3phase Kasco units will run in a clockwise rotation when looking down at the propeller/impeller. On J series units the upper pump housing must be removed to see the propeller/impeller. Stand clear of the propeller/impeller while verifying rotation. Follow the steps below.

Electrician:

1. Verify all screw terminal connections are tightened to specified torque setting prior to energizing the panel.
2. Verify the electrical service (voltage and Phase) matches the control panel and aerator nameplates ratings. Refer to your control panel instructions and schematics for installation details.

3. Verify all switches, circuit breakers, and motor starters are in the OFF position
4. Connect electrical service to your control panel as shown in the electrical schematic that came with the panel.
5. Connect the unit power cord to the panel as shown in the electrical schematic with your panel
6. Set the motor starter overload to the FLA rating on the aerator nameplate.
7. Pump rotation: Remove the upper pump housing (if you have a J series aerator) by removing the three screws attaching it to the lower pump housing. The pump rotation is clockwise when looking down at the propeller/impeller. Apply power to the control panel. Turn on the 15amp control circuit breaker, and motor starter.
8. Momentarily turn the Hand-Off-Auto switch to Hand. This will run the aerator. Do not run the aerator for more than a few seconds on shore. If the rotation is not correct. Disconnect and lock out power from the control panel. Swap any two of the aerator power cord wires in the panel. This will cause the motor to reverse direction. Reapply power to the panel and verify the rotation is clockwise.
9. Once rotation is verified, with the power disconnected and locked out again, reinstall the upper pump housing. Run the aerator one more time momentarily on shore to ensure the housing was reinstalled correctly. Disconnect and lock out power again and continue with installation of the aerator as detailed in the aerator owner's manual.

Record the following data while the unit is operating in the water under load:

Voltage:	Amperage:
L1-L2 _____	L1 _____
L1-L3 _____	L2 _____
L2-L3 _____	L3 _____

Current unbalance should not exceed 5% at full load

Installation Instructions

STEP ONE

Use the ropes to position the Unit in the desired location in the pond/lake (secure the cord near power source to prevent it from being dragged into the water). Anchor the ropes or secure them to the shoreline so the ropes are free of slack, but not tight. To prevent twisting of the unit due to torque, you should place the

anchor at least 3m from the float for every 1 meter of depth (Ex. A 3m deep pond would require an anchor 9m horizontally from the float.) For ease of removal, you may choose to keep at least one anchor within reach from shore, just below the water's surface.

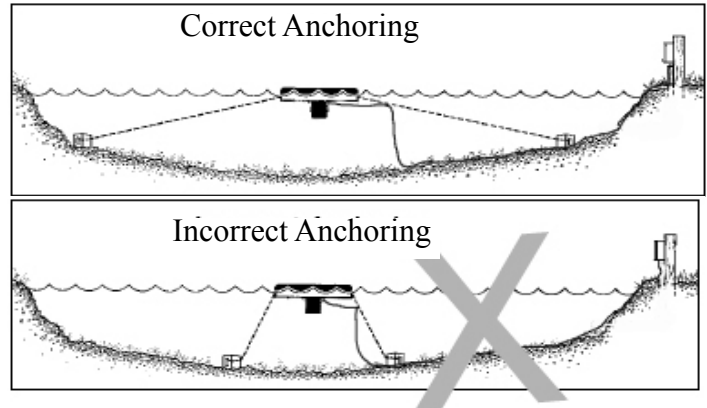

STEP TWO (ALTERNATE INSTALLATION)

In ponds where the water level fluctuates significantly, you may need to suspend a small weight (30cm of 2.54cm galvanized pipe works well) at the mid-point of the rope to take up any slack as the water level drops. The weight should be light enough so the Unit can rise as the water level rises. This can also help hide ropes by sinking them further below the surface.

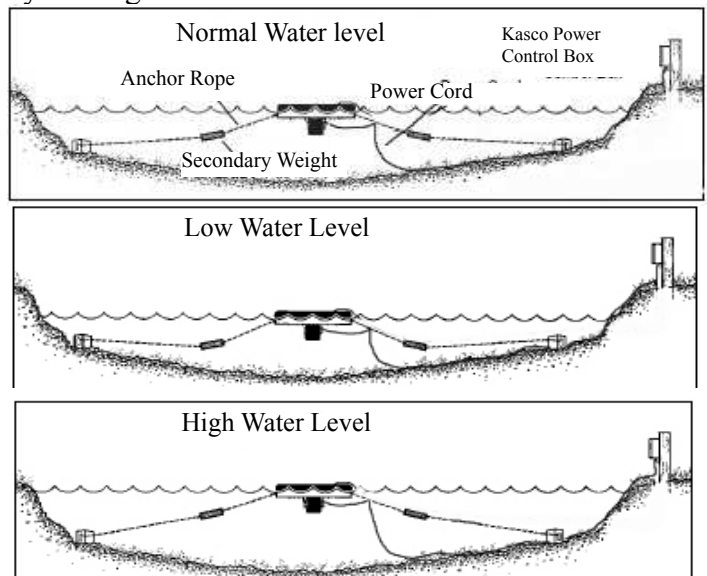

STEP THREE

At this time the Aerator is ready for operation. The unit can now be connected to the electrical circuit (fixed wiring) with a plug or direct wire connection. The circuit must be provided with a disconnect switch, short circuit, and ground fault protection (RCD). Refer to unit specs for voltage and amperage ratings. Also, the motor name plate lists the unit's electrical ratings. Electrical installation must follow local and national electrical codes and should be installed by a professional.

Circulator Parts (EC Models)

Circulator (Unit with cord or stub cord) (1)
 Float in separate box (1)

1. Float (1)
2. Base Strap (1)
3. Adjustment Bracket (1)
4. Angle Bracket (3)
5. Draw Band (1)
6. U-Bracket (2)
7. Spacer Bracket (2)
8. 1/4" x 1/2" Stainless Steel Bolt (8)
9. 1/4" x 1" Stainless Steel Bolt (3)
10. 1/4" x 1-1/4" Stainless Steel Bolt (2)
11. 1/4" Stainless Steel Lock Nut (8)
12. 1/4" Stainless Steel Hex Nut (2)
13. 1/4" Stainless Steel Lock Washer (5)
14. 50' Black Nylon Ropes (2)
15. Nylon Tie (1)

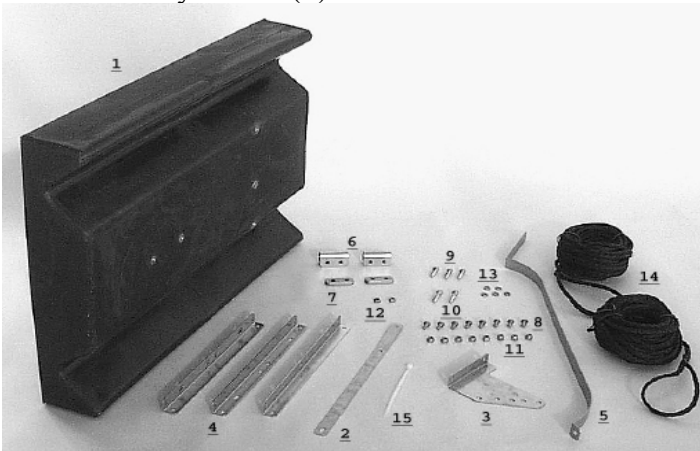

Circulator Tools & Supplies Needed

- A. Anchors or stakes for installing unit (2)
- B. 208-240V Electrical Supply near pond on a post
- C. 30cm pieces of 2.54cm galvanized pipe for weight-ing ropes (optional) (3)
- D. 9/16" (14mm) & 7/16" (11mm) Nut Driver
- E. 9/16" (14cm) & 7/16" (11mm) Socket
- F. Adjustable crescent wrench
- G. 7/16" Wrench (1)
- H. 7/16" Socket & Wrench (1)
- I. Felt-tip marker (1)

Circulator (EC Model) Assembly

STEP ONE

Remove all contents from package and place on a clean, flat surface. Inspect the shipment for any damages. Make sure you have all the parts needed.

STEP TWO

Position the Float (Part B1) upside down (lengthwise channels facing up) and place the Base Strap (Part B2)

so the three holes in the Base Strap align with the three threaded holes that comprise the lengthwise midline of the Float.

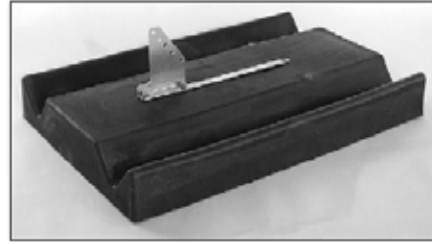

STEP THREE

Position the Adjustment Bracket (Part B3) over the two holes at the back end of the Float and Base Strap. Loosely secure the Adjustment Bracket to the Float using two 1/4" x 1/2" (Part B8) Stainless Steel Bolts and two Stainless Steel Lock Washers (Part B13). (See photo above for orientation.)

STEP FOUR

Place one of the three Angle Brackets (Part B4) perpendicular to the Base Strap at the front end of the Base Strap. One of the two center holes of the Angle Bracket should be positioned over the hole in the Base Strap and the threaded hole in the Float. Secure the Angle Bracket to the Float using three 1/4" x 1/2" Stainless Steel Bolts and three Stainless Steel Lock Washers. (See photos for specific instructions based on the size circulator purchased.) Tighten all hardware at this time with the 7/16" (11mm) socket and wrench.

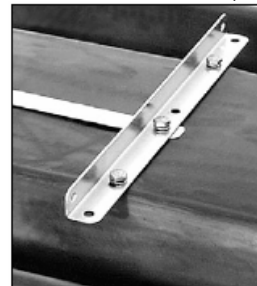

Models 2400
& 3400 - Angle
posterior to bolts.

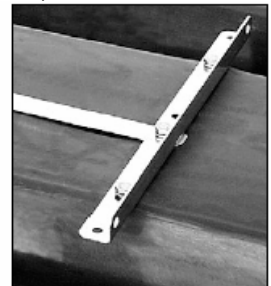

Model 4400 Angle
anterior to bolts.



STEP FIVE

With a felt-tip marker, draw three to four marks around the circumference of the motor housing at the appropriate measurement from the back (or bottom) of the motor housing given:

2400: 3/4" (1.9cm)

3400: 3-3/8" (8.57cm)

4400: 5-1/2" (14 cm)



bolts on the U-Brackets (See photo for orientation) with a 1/4" Lock Nut.



2400 & 3400

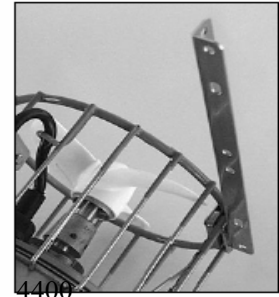

4400

STEP SIX

Place the two U-Brackets (Part B6) directly across from each other (180°) over the top ring of the motor cage. The cord clamp on the cage should be 90° from each of the U-Brackets

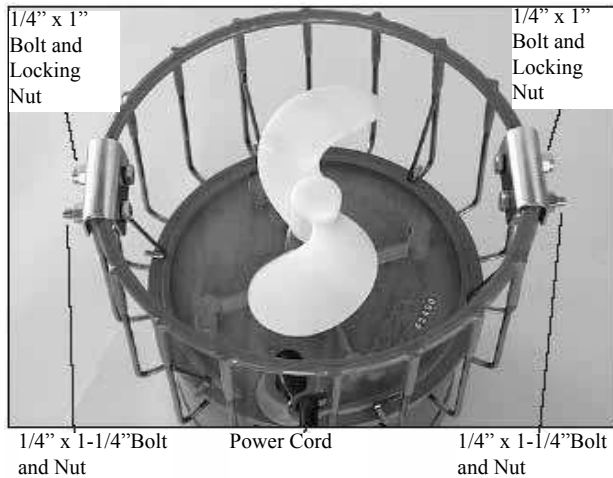

STEP NINE

Wrap the Draw Band (Part B5) around the motor housing and position so that the back of the Draw Band touches the marks drawn in Step Five. There is no front or back to the Draw Band itself - it is reversible. Orient the arm of the Draw Band so it aligns with the cord clamp on the cage of the motor housing and is parallel to the Angle Brackets attached in Step Eight. Secure using a 1/4" x 1" Stainless Steel Bolt and a 1/4" Lock Nut. (See photo in next column)



STEP SEVEN

Insert the Spacer Bracket (Part B7) under the U-Bracket and inside the cage. Secure this assembly using one 1/4" x 1" Bolt (Part B9) and a 1/4" Lock Nut (Part B11), and one 1/4" x 1-1/4" Bolt (Part B10) and a 1/4" Hex Nut (Part B12). The longer bolt should be on the side of the U-Bracket that is closer to the cord clamp. Tighten the hardware using the 7/16" (11mm) wrench and socket & wrench until the U-Bracket clamps firmly around the cage (U-Bracket should pull together slightly). Repeat with the second U-Bracket.

STEP TEN

Attach the Angle Bracket on the motor to the Angle Bracket on the Float using two 1/4" x 1/2" Bolts and two 1/4" Lock Nuts (one set for each Bracket). See photos for orientation based on model size. Also, the cord clamp on the cage should be oriented toward the Float.



STEP EIGHT

Attach an Angle Bracket to each of the longer (1-1/4")

Angle towards back Angle Towards front

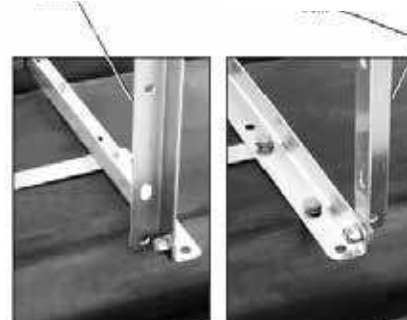

2400 & 3400

4400

STEP ELEVEN

Attach the Draw Band on the motor to the Adjustment

Bracket on the Float using a 1/4" x 1/2" Bolt and a 1/4" Lock Nut. Select one of the five possible positions to mount the Draw Band for your preferred direction of flow.

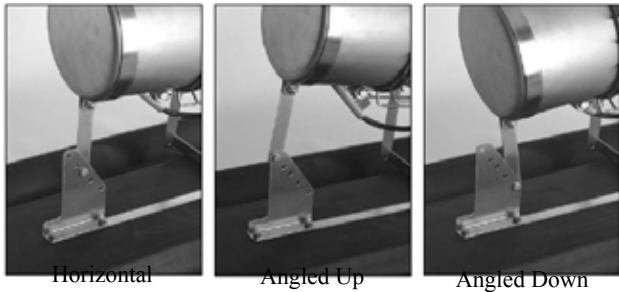

STEP TWELVE

Attach the Ropes to the front (on the cage) and back (around the Draw Band) of the motor. At this time, use the Nylon Tie provided to connect the power cord and front Rope to prevent the cord from tangling in the prop. Also, if the power cord has a Quick Disconnect and Additional Strain Relief install the Quick Disconnect and Strain Relief per instructions.

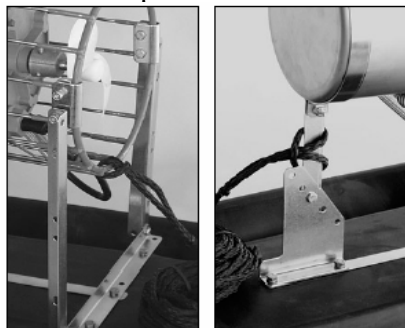

STEP THIRTEEN

Float the circulator in the water and position where desired. Tie the front Rope to a stake on the shore or weight. If a weight is used sink weight in front of unit so rope is taught. (Circulators create great force, make sure weight is enough to prevent movement.) Tie back Rope to a stake on opposite shore or weight. Sink weight behind the unit so rope is taught. At this time take up any slack in the line.

STEP FOURTEEN

The unit can now be connected to the electrical circuit (fixed wiring) with a plug or direct wire connection. The circuit must be provided with a disconnect switch, short circuit, and ground fault protection (RCD). Refer to unit specs for voltage and amperage ratings. Also, the motor name plate lists the unit's electrical ratings. Electrical installation must follow local and national electrical codes and should be installed by a professional.

Maintenance Recommendations

 Under No Circumstances should anyone enter the water while a unit is operating. Turn Off and Disconnect electrical power prior to any Maintenance or Servicing

RCD (Residual Current Device) or GFCI are a safety feature that can also alert you to electrical leaks in the equipment. It is extremely important to test the RCD upon installation, each reinstallation, and monthly thereafter to ensure proper operation. If you have repeat, consistent trips on your ground fault, the equipment should be disconnected and removed from the water. The power cord should be inspected for damage and you should call a Kasco Marine distributor or representative for further instructions.

If the supply cord becomes damaged, it must be replaced by an authorized service center, or similarly qualified persons in order to avoid a hazard.

OBSERVATION: Operating equipment should be observed on a regular basis (daily, if possible) for any reduction or variation in performance. If a change in performance is observed, the equipment should be disconnected from power and inspected for any material that may have clogged the system or wrapped around the shaft of the motor, especially plastic bags and fishing line. Even though Kasco Aerators & Circulators are among the most clog-resistant on the market, it is impossible to protect against all items that can clog equipment and still maintain a flow of water. These materials can be very damaging to the equipment under continued operation and must be removed as soon as possible. **ALWAYS DISCONNECT POWER TO THE UNIT BEFORE ATTEMPTING TO REMOVE CLOGS.**

WINTER STORAGE: In regions where there is significant freezing in the wintertime, Aerators should be removed from the water to protect them from the expansion pressure of the ice. In many areas, Aerators will keep some amount of ice open through the winter. However, when the water is thrust into the air, it is exposed to the colder air temperatures longer and can actually make ice thicker on the pond/lake. Storage over winter is best in a location that is out of the sun and cool, but above 0°C.

CLEANING: Equipment should be removed from the water at least once per year (at the end of the season in cold climates) to clean the exterior of the system, especially the stainless steel motor housing (can). The motor housing is the surface that dissipates heat into the water and any algae, calcium, etc. build-up will become an insulator that blocks heat transfer. In warmer regions it is recommended that the motor is removed and cleaned at least two to three times per year depending on conditions. In most cases a power washer will be sufficient if the unit and algae are still wet.

SEAL AND OIL REPLACEMENT: This is a sealed motor assembly and seals will wear out over time (similar to brake pads on a car). Replacement of the seals and a change of oil after three years may add longevity to the operation of the motor, saving you the cost of more expensive repairs. In warmer climates where the equipment runs most or all of the year, it is a good idea to replace seals more regularly than you would need to in colder climates where the unit is removed from the water for several months.

ZINC ANODE: A Sacrificial Zinc Anode is supplied on the shaft of all Kasco 50Hz Aerators & Circulators for protection of the equipment from corrosion and electrolysis. The zinc anode should be replaced if reduced to half the original size or if white in color. Corrosion from electrolysis is more commonly associated with saltwater or brackish water, but as a matter of precaution, it is important to periodically check the zinc anode in all installations (at least every two to three months).

Seal replacement and all other repair services should be performed by Kasco Marine or a Kasco trained Authorized Repair Center. Please contact your Kasco Marine, Inc. distributor or representative for your nearest Authorized Repair Center.



Pollution of the liquid could occur due to leakage of lubricants. If leakage is detected, shutdown and have the unit removed for repair.

Troubleshooting tips

The following is provided to help diagnose a probable source of trouble. It is a guideline only and may not show all causes for all problems. For additional troubleshooting help contact your local distributor or visit www.kascomarine.com for additional tips

Problem	Possible Cause	Likely Remedy
Unit does not start	<p>Power is off or disconnected</p> <p>RCD (residual current device), or GFCI (Ground fault circuit interrupter) is tripped.</p> <p>RCD continues to trip randomly.</p> <p>Tripped circuit breaker.</p> <p>Unit is jammed with debris and will not start.</p>	<p>Ensure unit is connected to the electrical circuit. Verify circuit breakers, timers, and/or interlock switches are turned on and functional.</p> <p>Reset the RCD or GFCI and restart the unit.</p> <p>If the unit continues to trip the RCD, this indicates a potential problem with the mains electrical service, power circuit feeding the unit, or the unit may have water in the power cord, or motor assembly. Contact your distributor for assistance to remedy this situation.</p> <p>Disconnect unit from electrical power. Check and remove any debris from the unit. Refer to the installation manual for further details on removing any guarding. Reconnect to electrical power and start unit to see if problem is resolved. If not, call your local distributor for assistance.</p>
Reduced performance	<p>Unit is clogged with debris</p> <p>Damaged propeller or impeller</p> <p>Low voltage to unit</p>	<p>Disconnect unit from electrical power. Check and remove any debris from the unit. Refer to the installation manual for further details on removing any components. Reconnect to electrical power and start unit to see if problem is resolved.</p> <p>Disconnect unit from electrical power. Check the propeller/Impeller for any chipping or damage that would cause the unit to not operate properly. Refer to installation instructions for assembly. Replace propeller / impeller if damage is found. Contact your distributor for assistance.</p> <p>Check the voltage at the power cord connection to verify the unit is receiving sufficient voltage to operate. Refer to installation instructions for voltage requirements. Checking this voltage while the circuit is loaded will verify if the voltage is stable. Remedy the voltage problem prior to operating the unit again.</p>
Unit starts and stops automatically or sporatically	Single phase unit - Internal overload is cycling	<p>Unit is getting too hot and is cycling the internal thermal overload in the motor.</p> <p>Disconnect Unit from electrical power.</p> <p>Remove unit from water and inspect for excessive debris buildup on the unit that would prevent heat dissipation into the water. Check the motor shaft can rotate freely. A build up of algae, calcium or organic matter on the stainless steel motor housing will reduce motor cooling. Clean unit and reinstall to test. If the unit continues to cycle on/off sporadically, then turn off and contact your distributor for repair.</p>